

**Combination Fire/Smoke Damper** ▲ 3 Hr. Rated ▲ Airfoil Blades ▲ Leakage Class II ▲ 250°F Rated ▲ Galvanized Steel ▲ For Volume Control Applications

### STANDARD MATERIALS AND CONSTRUCTION

- FRAME:** 5½" x 7/8" x 16 GA. galvanized steel hat channel. A flat head and sill are used for sizes less than or equal to 13" high.
- BLADES:** 20 GA galvanized steel double skinned (equal to 14 GA.), parallel action.
- AXLES:** Plated solid steel stub.
- BEARINGS:** Oil impregnated bronze.
- LINKAGE:** Plated steel angle and crank plates with stainless steel pivots, in-jamb type.
- STOPS:** 18 GA. galvanized steel at head and sill.
- BLADE SEALS:** Silicone.
- JAMB SEALS:** Stainless steel.
- SLEEVE:** Minimum 20 GA. galvanized steel by 18" long.
- CAULKING:** Hardcast Irongrip 601 or UL-listed equivalent.
- FINISH:** Mill on galvanized steel.
- ACTUATOR:** 24 VAC/DC Electric with heat response device (EHRD). Factory-installed for Power-Open/Spring-Close (fail close) operation. External left hand mounted as viewed from jack shaft side of damper.

### OPTIONS

- Exact Size (no undercut)
- Right Hand and/or Internal Actuator Mounting Locations (Restrictions Apply)
- Dual Position Indication (IDPI) Switches
- Sensotherm Re-Openable Heat Response Device (ESOT) for Electric Actuator
- Model SM-501 Flow-Rated Smoke Detector
- Model 2151 No-Flow Smoke Detector (12" Minimum Damper Height)
- Remote Test Box
- Momentary Test Switch
- Transformers
- Tab-Lock Retaining Angles
- Stainless Steel Bearings
- Stainless Steel Axles
- Sleeves of Various Depths and Gauge Thicknesses (restrictions apply)
- No Sleeve (restrictions apply)
- Round or Oval Transitions
- Security Bars
- Short-width (less than 8") and/or short-height (less than 6") transitions

### NOTES

1. Nominal deductions will be made to the opening size given.
2. Dampers greater than or equal to 12" in height with factory mounted SM-501 smoke detectors require a minimum 19" deep sleeve (10½" on the actuator side). Detectors will be mounted on the side of the damper opposite actuator.
3. Dampers less than 12" in height with factory mounted SM-501 smoke detectors require a minimum 20 deep sleeve (11½" on the actuator side). Detectors will be mounted on the bottom or top of damper.
4. Smoke Detectors can be ordered for field mounting with standard 18" deep sleeve.
5. Dampers for horizontal installation can only be mounted in a fire barrier constructed of masonry/concrete materials.
6. Actuator control signal is 2 -10 VDC or with additional of 500 ohm resistor (by other) is 4-20 mA.

### DAMPER SIZES

| Damper Style          | Temp. Rating (°F) | Velocity and Pressure | Minimum Panel (Horz & Vert)                      | Horizontal and Vertical           |                                   |
|-----------------------|-------------------|-----------------------|--|-----------------------------------|-----------------------------------|
|                       |                   |                       |  | Max Panel                         | Max Assy                          |
| No Transition         | 250°              | 2000 FPM, 4in. w.g.   | 8"W x 6" frame                                   | 24"W x 24"H frame                 | 60"W x 48"H frame                 |
| C-round or C-square   |                   |                       | 4" dia. duct or 4"W x 4"H duct (8"W x 6"H frame) | 28" dia. duct or 28"W x 28"H duct | 46" dia. duct or 46"W x 46"H duct |
| C-oval or C-rectangle |                   |                       | 4"W x 4" duct (8"W x 6"H frame)                  | 22"W x 22"H duct                  | 58"W x 46"H duct                  |

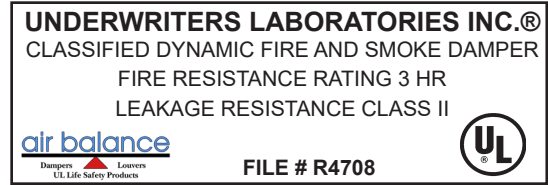

This combination fire/smoke damper meets the construction and performance requirements of:

- Underwriters Laboratories Inc. Standards 555 and 555S
- National Fire Protection Association Standards 80 and 90A
- ICC's International Building Code
- New York City MEA Listing #111-99-M
- California State Fire Marshal Listing #3225-1328:118
- Underwriters Laboratories Inc. Approved for dual direction airflow and dynamic conditions.
- Underwriters Laboratories Inc. Classified for use in fire resistive ratings of 3 hours and longer.
- Underwriters Laboratories Inc. Classified for use in smoke control systems for Leakage Class II and 250°F .
- Actuators must be arranged to operate automatically, must fail closed upon loss of power, and must be controlled by a smoke detection system.

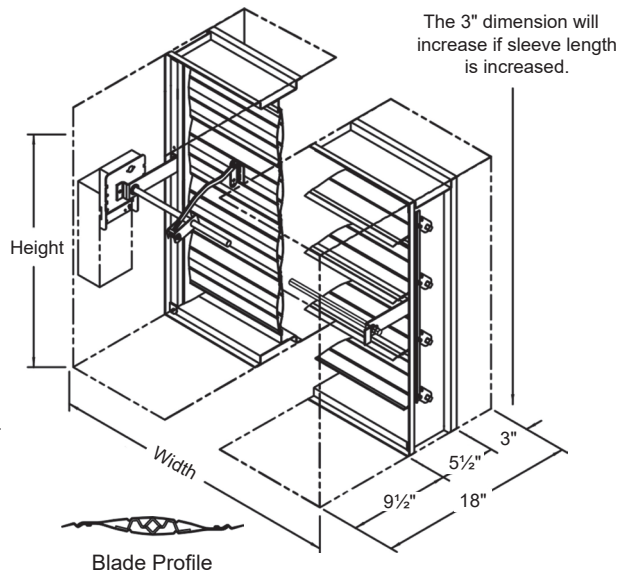

**Combination Fire/Smoke Damper** ▲ 3 Hr. Rated ▲ Airfoil Blades ▲ Leakage Class II ▲ 250°F Rated ▲ Galvanized Steel ▲ For Volume Control Applications

## OPERATIONAL RATING

Maximum Differential Pressure: 4 in. wg (6 in. wg for selected size/actuators combinations)  
 Maximum Velocity: 2000 fpm (4000 fpm for selected size/actuator combinations)

## LEAKAGE RATING

UL Leakage Class II

- 10 cfm per sq. ft. maximum @ 1 in. wg
- 20 cfm per sq. ft. maximum @ 4 in. wg
- 24.5 cfm per sq. ft. maximum @ 6 in. wg

## PRESSURE DROP RATING

The Pressure drop data shown below is based on laboratory conditions. The test setup does not take into account elbows or other duct fittings that are part of every actual duct system. The configuration of the actual duct system immediately upstream and downstream of the damper often contributes more pressure loss than the damper itself.

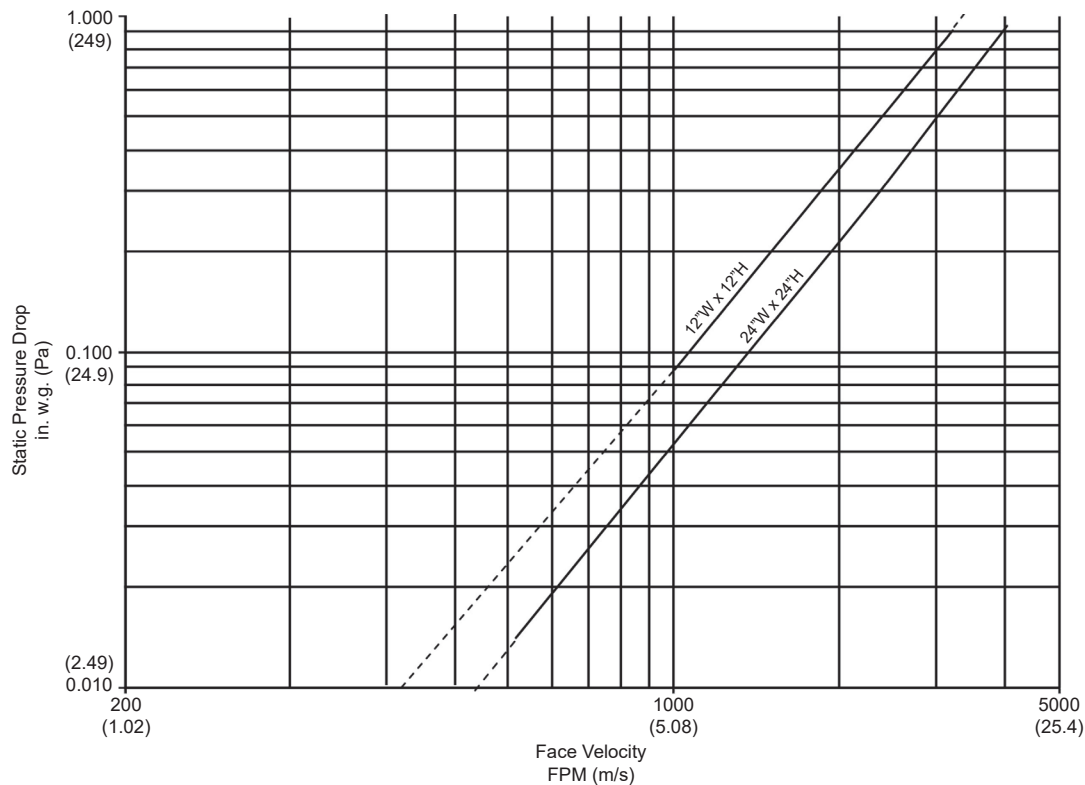

This product was tested in accordance with AMCA Standard 500D, Figure 5.3.  
 Intake air converted to standard air density.

|                      |            |                    |                    |          |                     |                           |             |   |
|----------------------|------------|--------------------|--------------------|----------|---------------------|---------------------------|-------------|---|
|                      |            |                    |                    |          |                     |                           |             |  |
| <b>Item #</b>        | <b>Qty</b> | <b>Damper Size</b> | Horizontal         | Vertical | 250°F               | Velocity                  | Pressure    |   |
|                      |            |                    | <b>Orientation</b> |          | <b>Temp. Rating</b> | <b>Operational Rating</b> |             | <b>Union Made</b>   |
| <b>Arch. / Eng.:</b> |            |                    |                    |          | <b>EDR:</b>         |                           | <b>ECN:</b> | <b>Job:</b>   |
| <b>Contractor:</b>   |            |                    |                    |          |                     |                           |             |   |
| <b>Project:</b>      |            |                    |                    |          | <b>Date:</b>        |                           | <b>DWN:</b> | <b>DWG:</b>   |